

CU Blowdown Valve

Part Number: CU81600-1, 2, 3

Water quality can affect efficiency or result in boiler damage if neglected. Boiler feedwater contains impurities in solution and suspension. These impurities concentrate in the boiler. The concentration of these impurities increases as more feedwater is introduced into the boiler and steam is produced. If the suspended solids are allowed to concentrate beyond certain limits, a deposit or "scale" will form on the boiler internal surfaces. This deposit can interfere with the proper boiler operation and cause boiler failure.

The concentration of these impurities is generally controlled by the feedwater quality and by blowdown. Blowdown refers to removing a portion of the boiler water with high solids concentration and replacing it with makeup water of a lower concentration.

CAUTION To maintain safe operation of the Blowdown Valve make sure all pipes succeeding the valve are rated to operate with hot water and are properly insulated. To adhere to National and local plumbing and building codes a ASME code blowdown separator tank may need to be installed.

Operation

The blowdown valve is used in conjunction with the blowdown timer. The blowdown timer is to be wired to the valve in accordance with the procedure explained in the Boiler Installation, Operation and Maintenance Manual (PUR 100376).

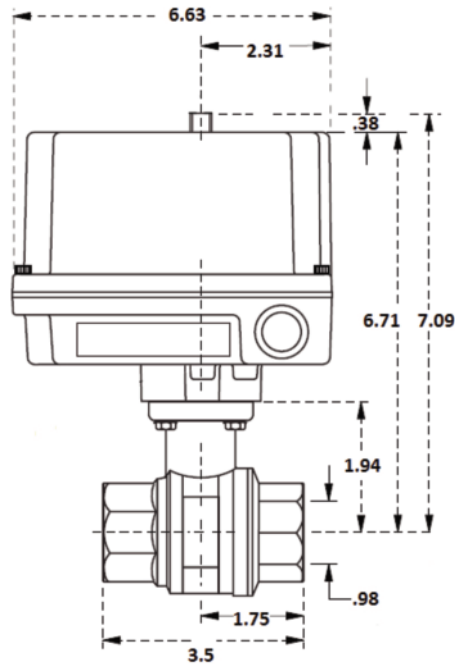

Technical Data

- 1" valve size
- Triple Stem Seal Design
- Stainless Steel Valve Body
- NTP Threaded Ends to ANSI B2.1
- Internal Blow-Out Proof Stem
- Meets WW-V-35 Design Specifications
- 115 VAC, 60Hz, 1 PH. PSC
- Thermal overload protection
- Temperature Range: -40°F - 150°F
- CSA Certified
- .55 Locked rotor Amps
- Cast Aluminum casing with Stainless steel output shaft and fasteners

FOR ILLUSTRATIVE PURPOSES ONLY. IMPORTANT NOTE: FOR SAFE AND TROUBLE FREE INSTALLATION

visit mrsteam.com before installation to download the Installation, Operation and Maintenance Manual or refer to the manual provided with the unit.

MODEL	PROJECT INFORMATION	
<input type="checkbox"/> CU81600-1 (used on CU360-1400)	Location:	Contractor:
<input type="checkbox"/> CU81600-2 (used on CU2000-2500)	Architect:	Submitted By:
<input type="checkbox"/> CU81600-3 (used on CU4500)	Engineer:	Date:
	Notes:	